



Bulletin HY14-2536-M6/US
Service Bulletin

Series D1VW, H Style 91 Design

Effective: May 1, 2007

Directional Control Valves

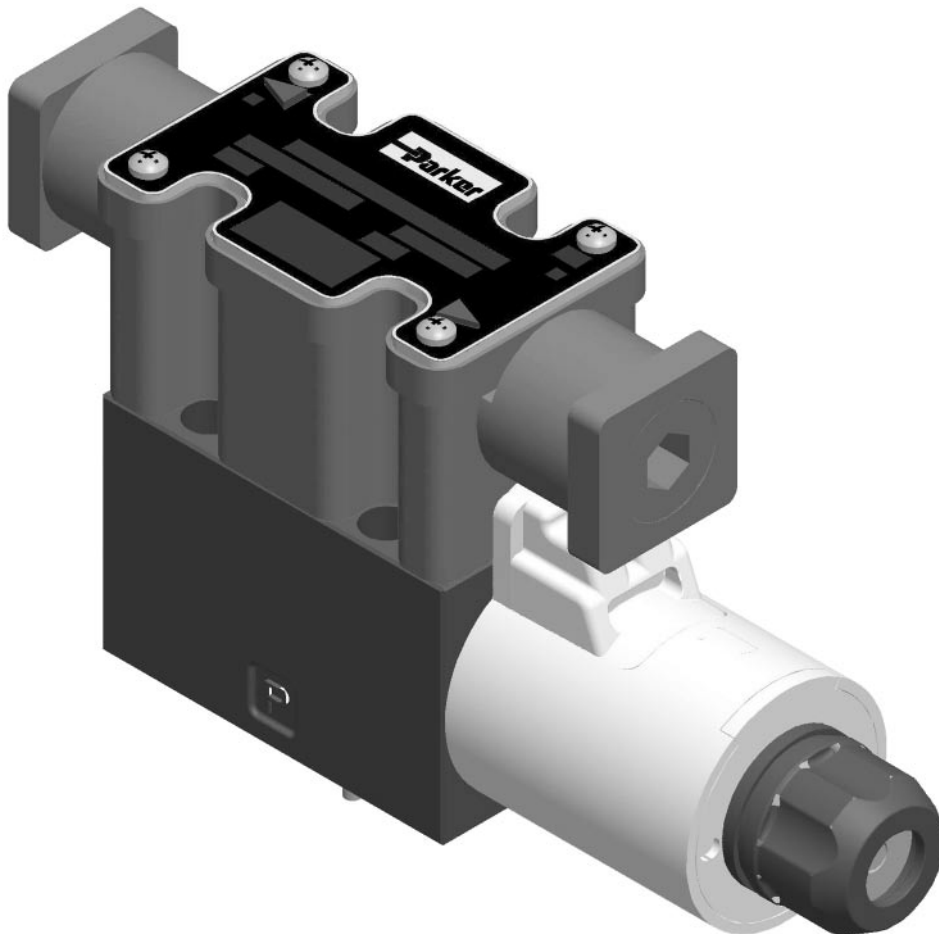

**WARNING – USER RESPONSIBILITY**

FAILURE OR IMPROPER SELECTION OR IMPROPER USE OF THE PRODUCTS DESCRIBED HEREIN OR RELATED ITEMS CAN CAUSE DEATH, PERSONAL INJURY AND PROPERTY DAMAGE.

- This document and other information from Parker-Hannifin Corporation, its subsidiaries and authorized distributors provide product or system options for further investigation by users having technical expertise.
- The user, through its own analysis and testing, is solely responsible for making the final selection of the system and components and assuring that all performance, endurance, maintenance, safety and warning requirements of the application are met. The user must analyze all aspects of the application, follow applicable industry standards, and follow the information concerning the product in the current product catalog and in any other materials provided from Parker or its subsidiaries or authorized distributors.
- To the extent that Parker or its subsidiaries or authorized distributors provide component or system options based upon data or specifications provided by the user, the user is responsible for determining that such data and specifications are suitable and sufficient for all applications and reasonably foreseeable uses of the components or systems.

OFFER OF SALE

The items described in this document are hereby offered for sale by Parker-Hannifin Corporation, its subsidiaries or its authorized distributors. This offer and its acceptance are governed by the provisions stated in the detailed "Offer of Sale" elsewhere in this document or available at www.parker.com/hydraulicvalve.

SAFETY GUIDE

For safety information, see Safety Guide SG HY14-1000 at www.parker.com/safety or call 1-800-CParker.

© Copyright 2007, Parker Hannifin Corporation, All Rights Reserved

Bul HY14-2536-M6.indd, dd



Model Code

Standard Valves.....1-2

Parts Data

D1VW***H**G5*-91 (Conduit Box, Plug-In).....3

D1VW***H**C*-91* (Conduit Box, Leadwire)4

D1VW***H**P*-91, D1VW***H**W*-91, D1VW***H**S*-91, D1VW***H**M*-91 (DIN, Spade, Metri-Pak).....5

D1VW***H**GGS*5*-91 (Conduit Box, Soft Shift, Plug-In).....6

D1VW***H**PGS*-91 (DIN Soft Shift)7

D1VW***H**EU-91, D1VW***H**ED-91, D1VW***H**EE-91, D1VW***H**EO-91 (Explosion Proof).....8

Ordering Information9-11

Spool Chart 11

Wiring Instructions12-13

Coil Data 14

Troubleshooting Guide15-16

Standard Valves

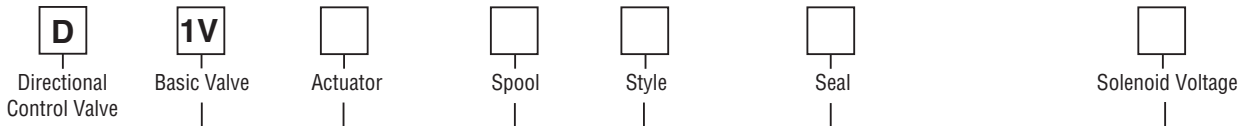

NFPA D03
CETOP 3
DIN NG6

Code	Description
W*	Solenoid, Wet Pin, Screw-in
HW*	Reversed Wiring

Code	Description
N	Nitrile
V	Fluorocarbon
E*	EPR

Code	Description
A**	24/50 VAC
D	120 VDC
G	198 VDC
J	24 VDC
K	12 VDC
L	6 VDC
N***	220/50 VAC
P***	110/50 VAC
Q**	100/60 VAC
QD	100/60 - 100/50 VAC
R	24/60 VAC
T	240/60 - 220/50 VAC
U	98 VDC
Y	120/60 - 110/50 VAC
Z	250 VDC

* Valve schematic symbols are per NFPA/ANSI standards, providing flow P to A when energizing solenoid A. Note operators reverse sides for #008 and #009 spools. See installation information for details. To configure per DIN standards (A coil over A port, B coil over B port) code valves as D1VHW***.

* Contact HVD for availability.

** High Watt only
*** Explosion Proof only.

Code	Symbol	Code	Symbol
001		011	
002		014	
003		015	
004		016	
005		020*	
006		026*	
007		030**	
008*, 009**		081	
010		082	

* 008, 020 & 026 spools have closed crossover.
** 009 & 030 spool have open crossover.
See Universal Spool Chart for other spool options.

Code	Description	Symbol
B*	Single solenoid, 2 position, spring offset. P to A and B to T in offset position.	
C	Double solenoid, 3 position, spring centered.	
D†	Double solenoid, 2 position, detent.	
E	Single solenoid, 2 position, spring centered. P to B and A to T when energized.	
F‡	Single solenoid, 2 position. Spring offset, energized to center. Position spool spacer on A side. P to A and B to T in spring offset position.	
H*	Single solenoid, 2 position, spring offset. P to B and A to T in offset position.	
K	Single solenoid, 2 position, spring centered. P to A and B to T when energized.	
M‡	Single solenoid, 2 position, spring offset, energized to center position. Spool spacer on B side. P to B and A to T in spring offset position.	

* 020, 026 and 030 spools only.
† 020 and 030 spools only.
‡ High Watt only.

Bold: Designates Tier I products and options.

**Non-Bold: Designates Tier II products and options.
These products will have longer lead times.**

Standard Valves

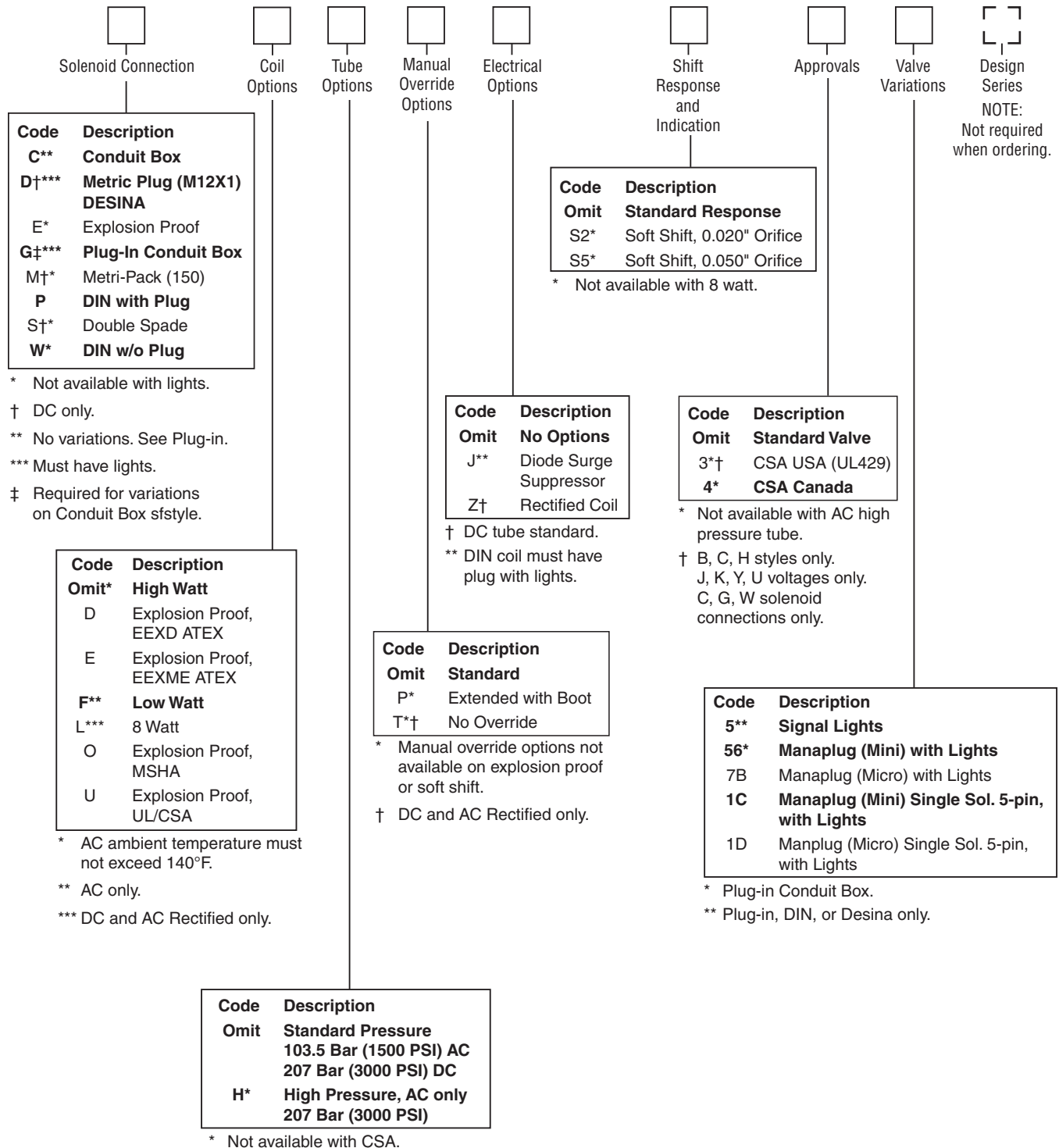

Bold: Designates Tier I products and options.

**Non-Bold: Designates Tier II products and options.
These products will have longer lead times.**

D1VW*H**G5*-91 Conduit Box, Plug-in**

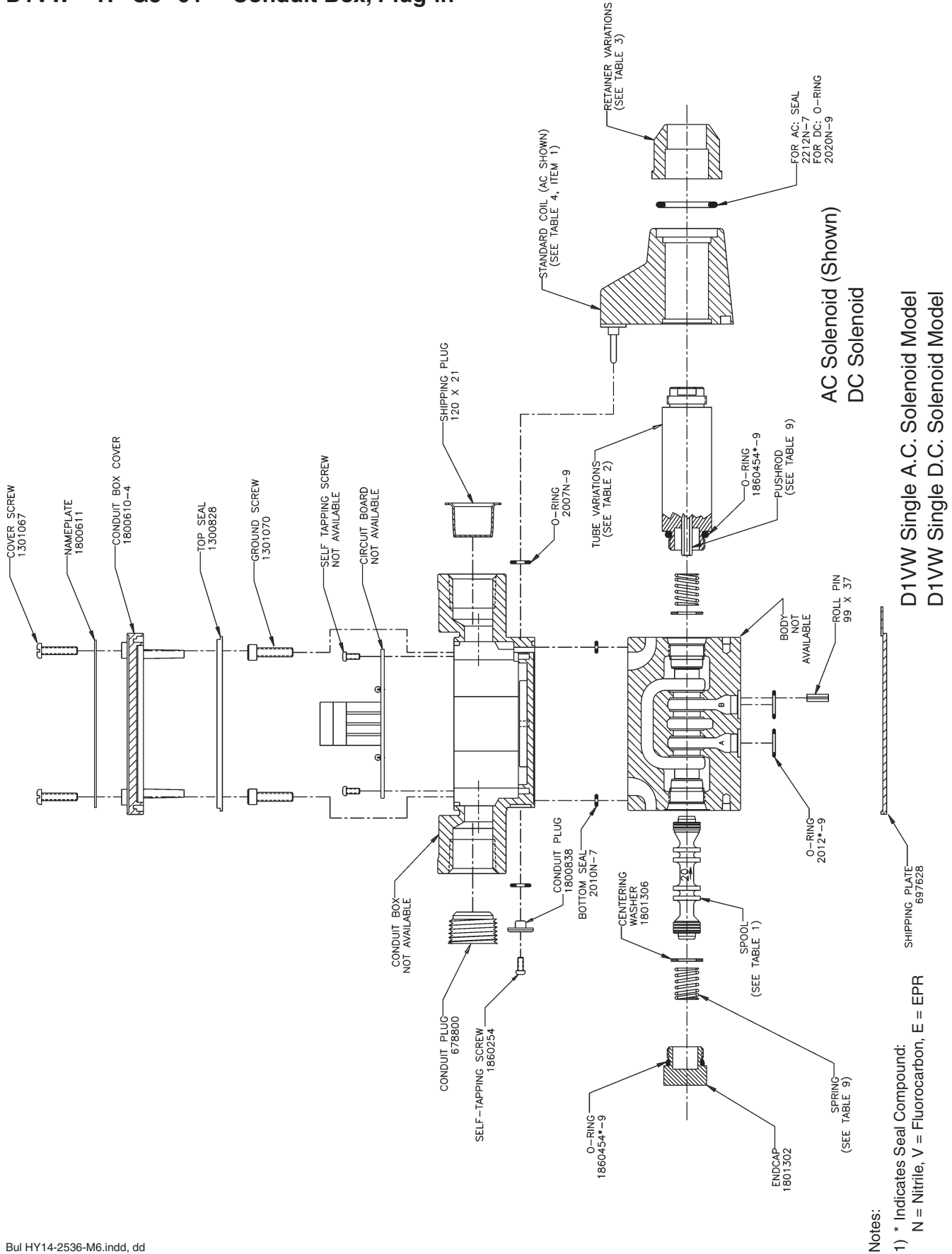

Notes:

- 1) * Indicates Seal Compound:
 N = Nitrile, V = Fluorocarbon, E = EPR



D1VW*H**C*-91 Conduit Box, Leadwire**

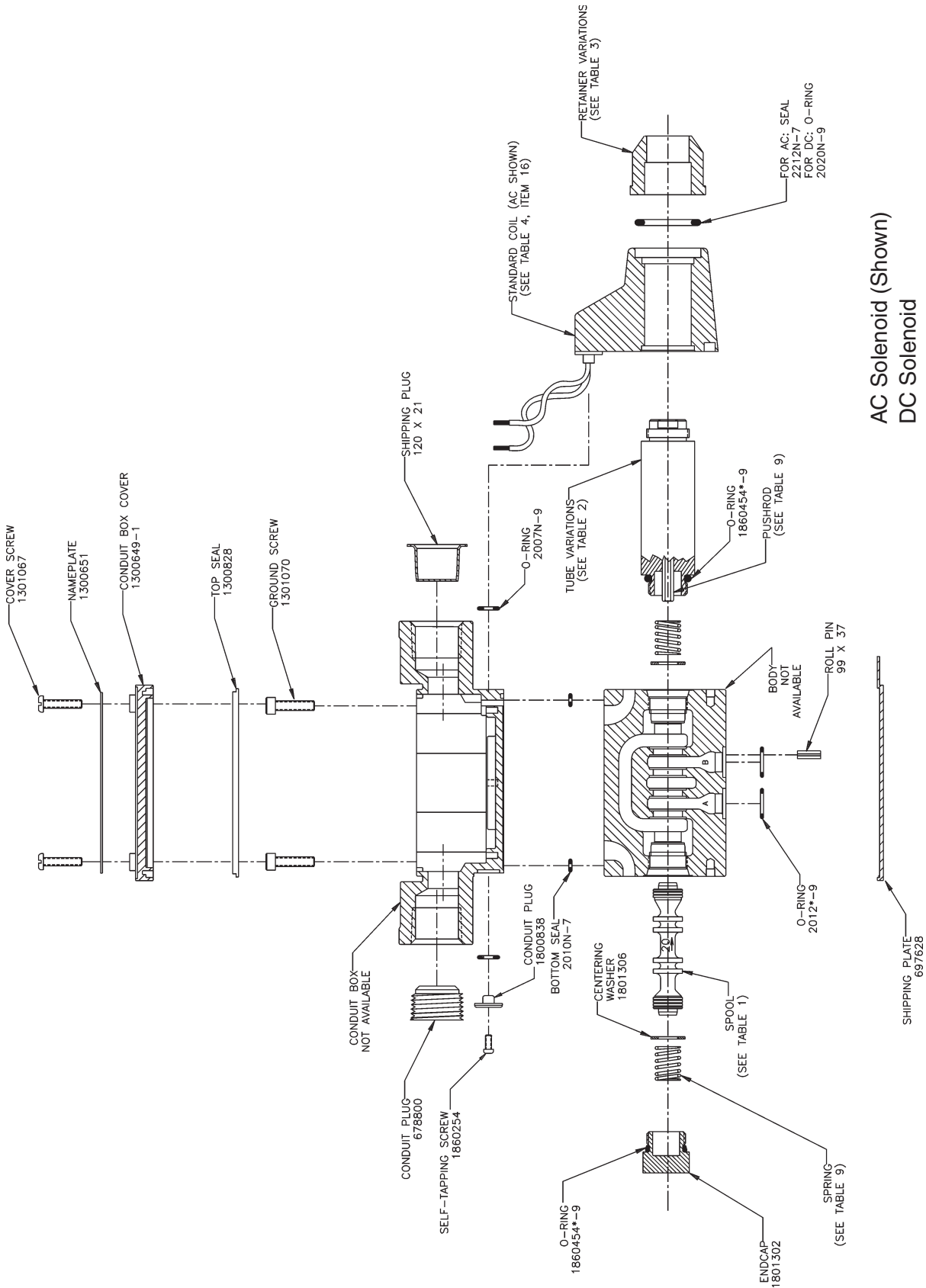

AC Solenoid (Shown)
 DC Solenoid

D1VW Single A.C. Solenoid Model
 D1VW Single D.C. Solenoid Model

- Notes:
 1) * Indicates Seal Compound:
 N = Nitrile, V = Fluorocarbon, E = EPR

D1VW*H**P*-91**
D1VW*H**W*-91**

DIN with Plug
DIN without Plug

D1VW*H**S*-91**
D1VW*H**M*-91**

Dual Spade
Metri-Pack

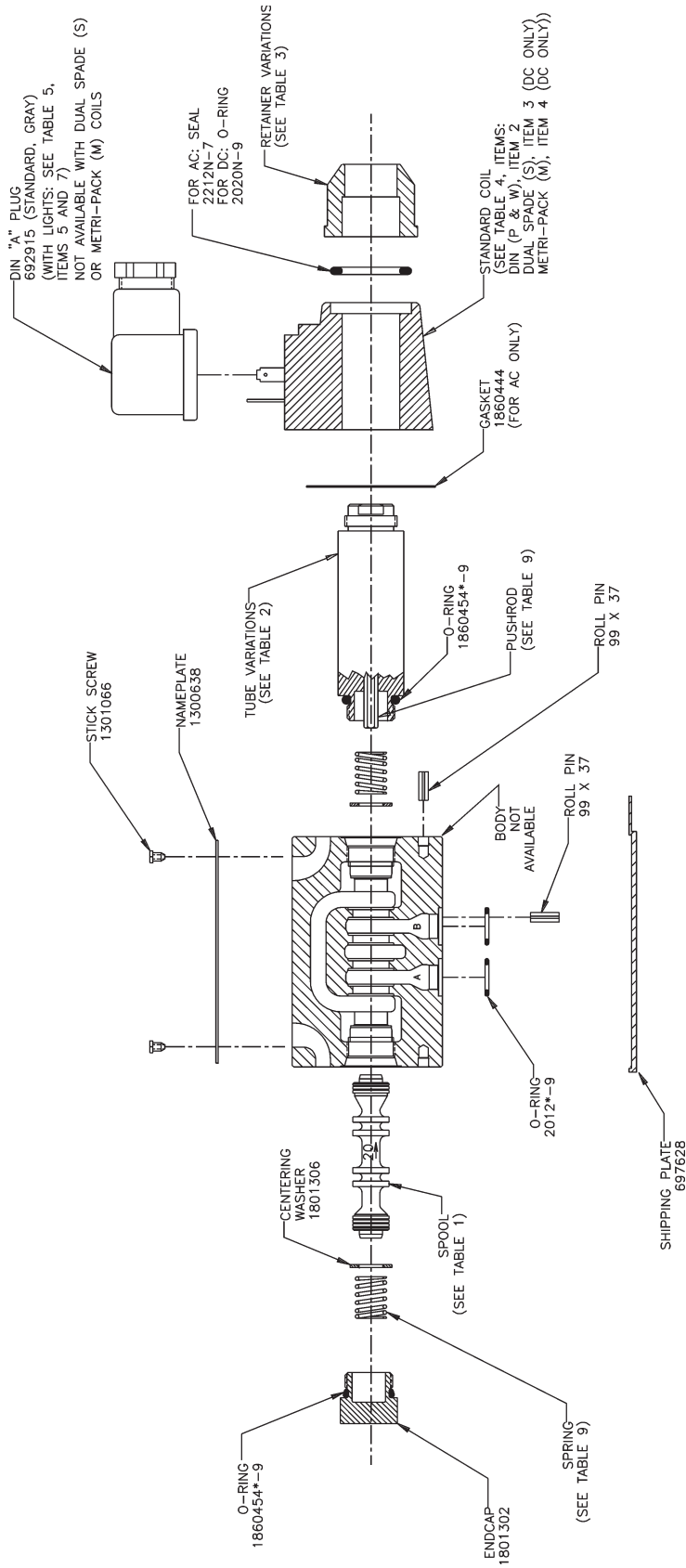

AC Solenoid (Shown)
 (Not available with 8 watt option)
DC Solenoid

D1VW Single A.C. Solenoid Model
D1VW Single D.C. Solenoid Model

Note:
 1) * Indicates Seal Compound:
 N = Nitrile, V = Fluorocarbon, E = EPR



D1VW*H**GG5*5*-91 Conduit Box Soft Shift, Plug-in**

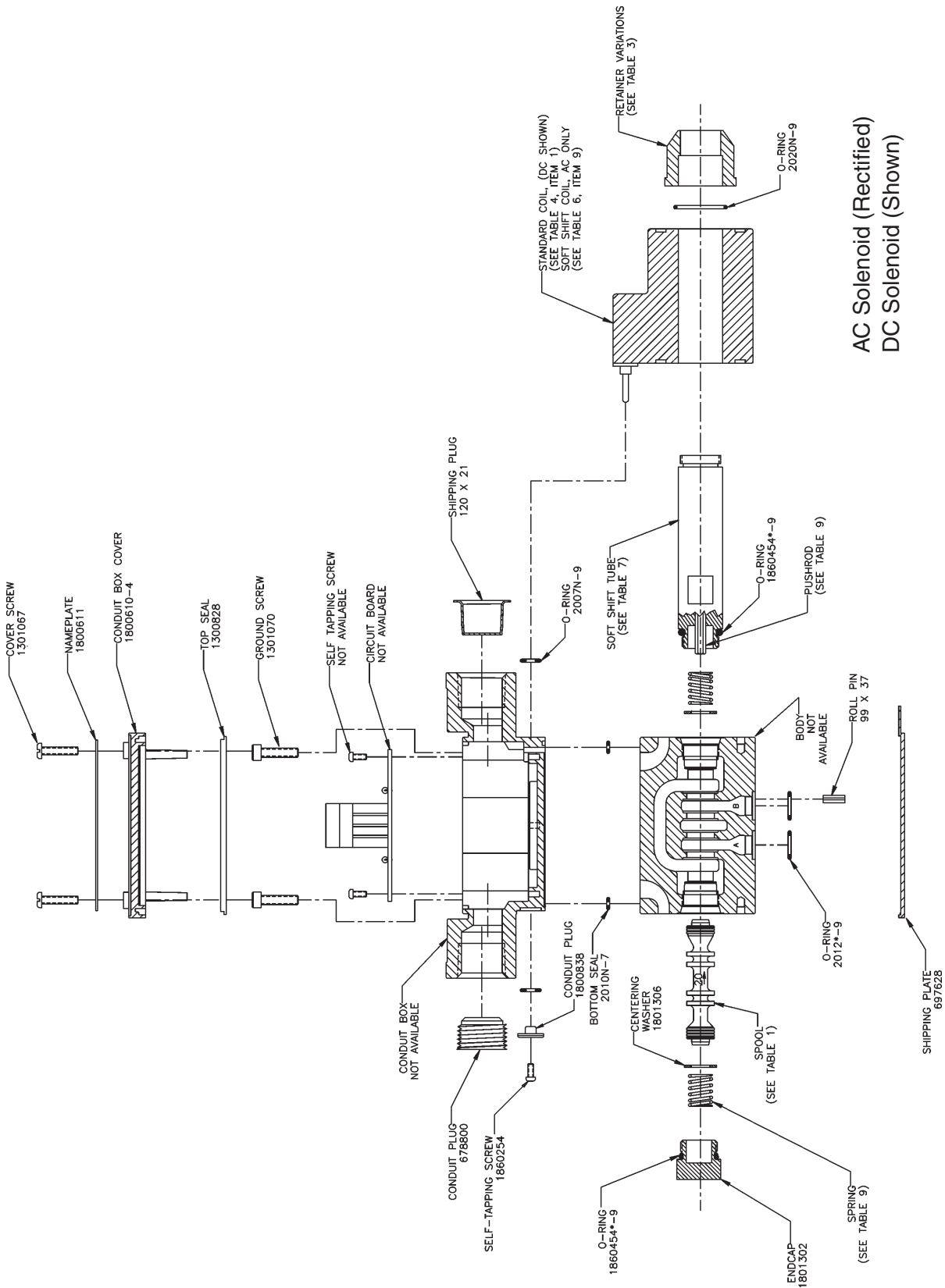

AC Solenoid (Rectified)
 DC Solenoid (Shown)

D1VW Single A.C. Solenoid Model
 D1VW Single D.C. Solenoid Model

Notes:
 1) * Indicates Seal Compound:
 N = Nitrile, V = Fluorocarbon, E = EPR

D1VW*H**PGS*-91 DIN Soft Shift with Plug (Required with AC)**
D1VW*H**WGS*-91 DIN Soft Shift without Plug (DC Only)**

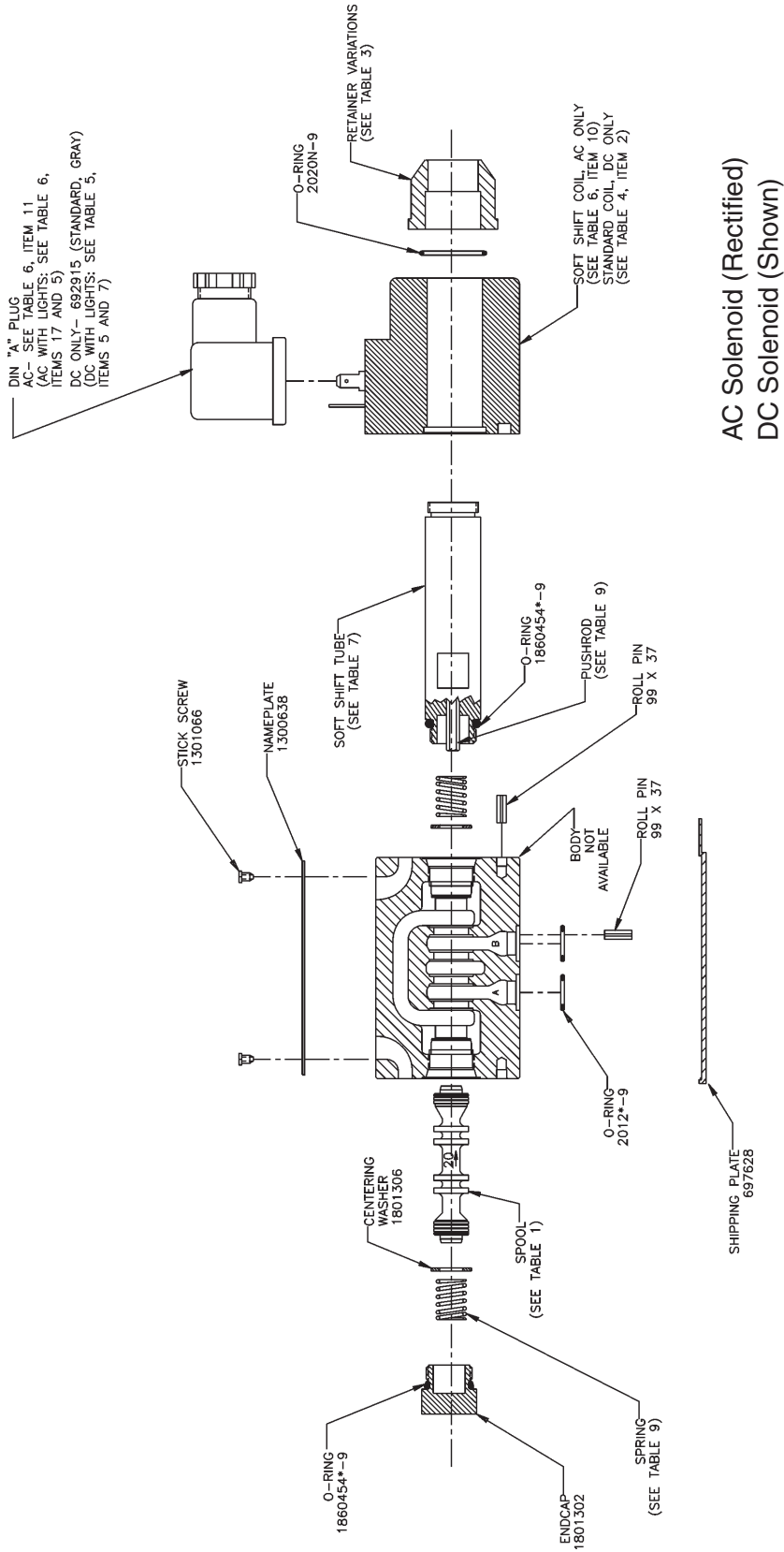

AC Solenoid (Rectified)
DC Solenoid (Shown)

D1VW Single A.C. Solenoid Model
D1VW Single D.C. Solenoid Model

Note:
1) * Indicates Seal Compound:
N = Nitrile, V = Fluorocarbon, E = EPR

D1VW*H**EU-91**
D1VW*H**ED-91**

UL / CSA
ATEX EEXD

D1VW*H**EE-91**
D1VW*H**EO-91**

ATEX EEXME
MSHA

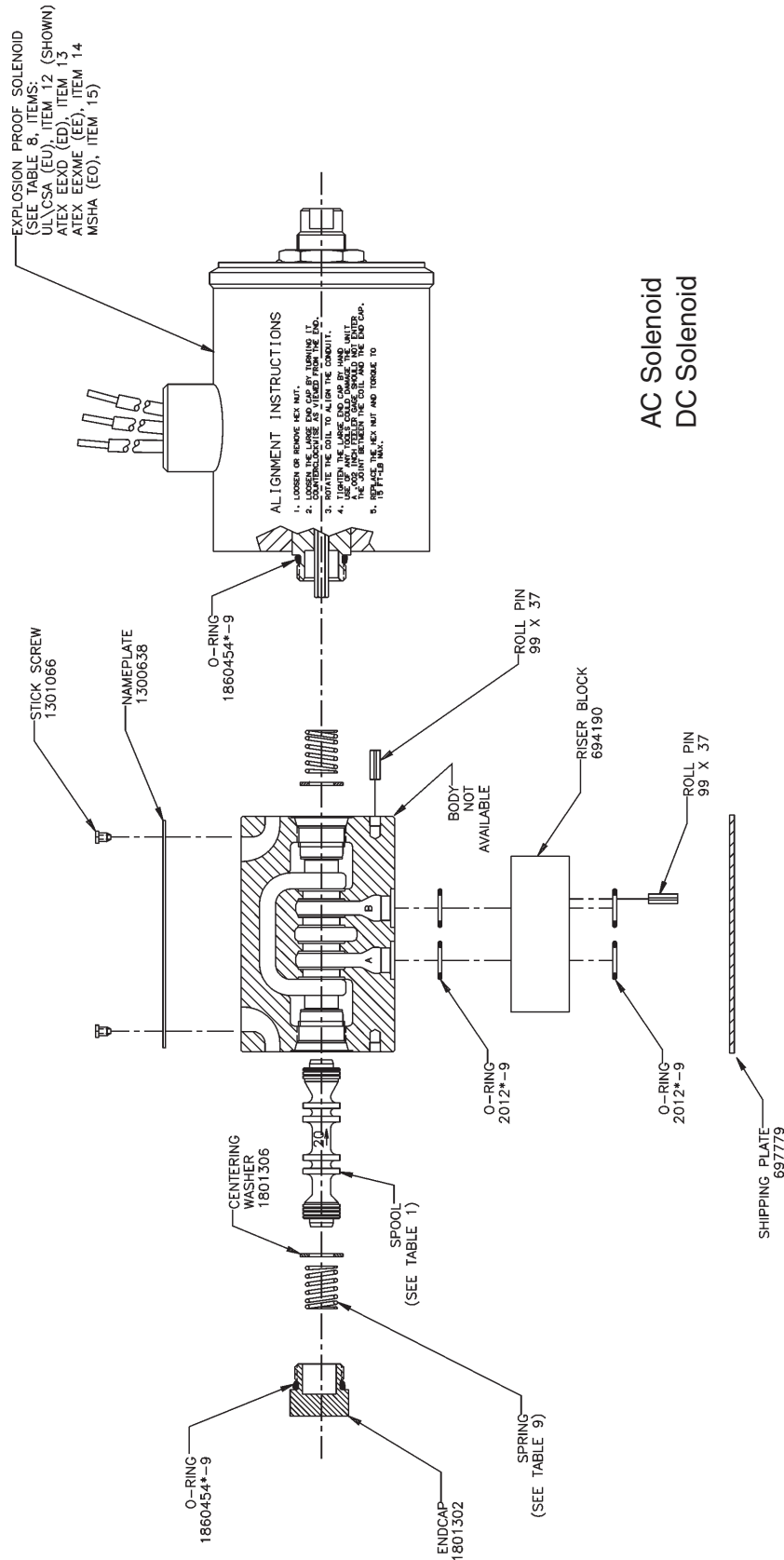

Note:
 1) * Indicates Seal Compound:
 N = Nitrile, V = Fluorocarbon, E = EPDM

Code	Part Number	Qty	Description
20	697620	1	#20 Spool
26	1300209	1	#26 Spool
30	697630	1	#30 Spool



Arrow points toward "B" port for all spools.

Code	Part Number	Qty	Description
Omit or F	1860432	1	A.C. Tube 1500 PSI
H	1860431	1	A.C. Tube 3000 PSI
G	1860428		D.C. Tube 3000 PSI
P or FP	1860434	1	Extended A.C. Tube 1500 PSI
HP or FHP	1860433	1	Extended A.C. Tube 3000 PSI
GP or LGP	1860429		Extended D.C. Tube 3000 PSI

Code	Part Number	Qty	Description
All Except P & T	1860456	1	AC Standard Retainer
	1860437		DC Standard Retainer
P or FP HP or FHP	1860463	1	AC Extended Override Retainer
	1860452		AC Extended Override Boot
P GP or LGP	1860437	1	DC Extended Override Retainer
	1860452		DC Extended Override Boot
T	1860438	1	DC Tamper Proof Retainer

Code	Item	Part Number	Qty	Description
All	5	697047	1	Label – "A" Solenoid
YP*5	7	694936	1	Plug with Light, 100-120V
QP*5		694936	1	Plug with Light, 100-120V
QDP*5		694936	1	Plug with Light, 100-120V
TP*5		694936	1	Plug with Light, 240V
KP*5		694935	1	Plug with Light, 12V
JP*5		694935	1	Plug with Light, 24V
DP*5		694936	1	Plug with Light, 100-120V

Solenoid Connection			G (Conduit Box) (Plug-In)	P & W (DIN)	S (Dual Spade)	M (Metri-Pack)	C (Conduit Box) (Leadwire)
	Item	Qty	1	2	3	4	16
Code	Description		Part Number	Part Number	Part Number	Part Number	Part Number
Y*	120/60–110/50 VAC 21 Watt	1	1860422-21-Y	1860423-21-Y	N/A	N/A	1860436-21-Y
T*	240/60–220/50 VAC 21 Watt	1	1860422-21-T	1860423-21-T	N/A	N/A	1860436-21-T
QD	100/60–100/50 VAC	1	N/A	1860423-25-QD	N/A	N/A	N/A
R*	24/60 21 Watt	1	1860422-21-R	N/A	N/A	N/A	1860436-21-R
L*	6 VDC	1	1860410-30-6	1860414-30-6	1860415-30-6	1860413-30-6	1860435-30-6
K*	12 VDC	1	1860410-30-12	1860414-30-12	1860415-30-12	1860413-30-12	1860435-30-12
KL	12 VDC 8 Watt	1	1860410-10-12	1860414-10-12	1860415-10-12	1860413-10-12	1860435-10-12
J*	24 VDC	1	1860410-30-24	1860414-30-24	1860415-30-24	1860413-30-24	1860435-30-24
JL	24 VDC 8 Watt	1	1860410-10-24	1860414-10-24	1860415-10-24	1860413-10-24	1860435-10-24
D*	120 VDC	1	1860410-30-120	1860414-30-120	1860415-30-120	1860413-30-120	1860435-30-120
DL	120 VDC 8 Watt	1	1860410-10-120	1860414-10-120	1860415-10-120	1860413-10-120	1860435-10-120
Z*	250 VDC	1	1860410-30-250	1860414-30-250	1860415-30-250	1860413-30-250	1860435-30-250
ZL	250 VDC 8 Watt	1	1860410-10-250	1860414-10-250	1860415-10-250	1860413-10-250	1860435-10-250
U*	98 VDC	1	N/A	1860414-30-98	N/A	1860413-30-98	N/A
G*	198 VDC	1	N/A	1860414-30-198	N/A	1860413-30-198	N/A

Table 6 – Soft Shift Coils, AC Rectified Only

Solenoid Connection			G (Conduit)	P (DIN w/Plug)	DIN Plugs, AC Rectified Only**			
Item			9	10				
Code	Description	Qty	Part Number	Part Number	Item	Description	Qty	Part Number
Y*G	120/60–110/50 VAC	1	1860410-30-98	1860414-30-98	11	Rectified Standard, Plug "B"	1	1301053
T*G	240/60–220/50 VAC	1	1860410-30-214	1860414-30-214	17	Rectified with Lights, Plug "B"	1	1300712
QD*G	100/60–100/50 VAC	1	1860410-30-86	1860414-30-86				

**Must be rectified plug when using AC with soft shift.

Table 7 – Soft Shift Tubes, DC or AC Rectified

Code	Part Number	Qty	Description
GS2	1860430-2	1	3000 PSI Soft Shift Tube, .020" Orifice
GS3	1860430-3	1	3000 PSI Soft Shift Tube, .030" Orifice
GS4	1860430-4	1	3000 PSI Soft Shift Tube, .040" Orifice
GS5	1860430-5	1	3000 PSI Soft Shift Tube, .050" Orifice

Table 8 – Explosion Proof Coils

Solenoid Connection			U (UL/CSA)	D (EEXD)	E (EEXME)	O (MSHA)
Item			12	13	14	15
Code	Description	Qty	Part Number	Part Number	Part Number	Part Number
YE	120/60–110/50 VAC	1	1860427-27-Y	1860424-25-Y	1860425-30-Y	1860426-27-Y
TE	240/60–220/50 VAC	1	1860427-27-T	1860424-25-T	1860425-30-T	1860426-27-T
QE	100/60 VAC	1	1860427-27-Q	1860424-25-Q	1860425-30-Q	1860426-27-Q
RE	24/60 VAC	1	1860427-27-R	N/A	1860425-30-R	1860426-27-R
AE	24/50 VAC	1	N/A	1860424-17-A	1860425-30-A	N/A
NE	220/50 VAC	1	1860427-27-N	1860424-25-N	1860425-30-N	N/A
PE	110/50 VAC	1	1860427-27-P	1860424-25-P	1860425-30-P	N/A
LE	6 VDC	1	1860421-33-6	1860418-33-6	1860419-30-6	1860420-33-6
KE	12 VDC	1	1860421-33-12	1860418-33-12	1860419-30-12	1860420-33-12
JE	24 VDC	1	1860421-33-24	1860418-33-24	1860419-30-24	1860420-33-24
DE	120 VDC	1	1860421-33-120	1860418-33-120	1860419-30-120	1860420-33-120
ZE	250 VDC	1	1860421-33-250	1860418-33-250	1860419-30-250	1860420-33-250

Table 9 – D1VW-91 Springs and Pushrods

Valve	Spool	Description	Style	Spring			Pushrod						
				1860447	1860446	1860445	1860400	1860401	1860402	1860403	1860404	1860439	1860441
Standard (Non-Soft Shift) Valve	1, 4, 10, 11, 21, 22	DC-8W	All Except F/M										
		DC-30W	All Except F/M										
		AC-21W	All Except F/M										
		AC-30W	All Except F/M										
		DC-8W	F & M										
		DC-30W	F & M										
	2, 3/15, 5/16, 6, 7, 8, 9, 14, 16, 20, 30	DC-8W	All Except F/M										
		DC-30W	All Except F/M										
		AC-21W	All Except F/M										
		AC-30W	All Except F/M										
		DC-8W	F & M										
		DC-30W	F & M										
	20D/30D	DC-8W	D										
		DC-30W	D										
		AC-21W	D										
		AC-30W	D										
	81/82	DC-8W	All Except F/M										
		DC-30W	All Except F/M										
	Soft Shift Valve	1, 4, 10, 11, 21, 22	DC-30W	All Except F/M									
			DC-30W	F & M									
2, 3/15, 5/16, 6, 7, 8, 9, 14, 20, 30		DC-30W	All Except F/M										
		DC-30W	F & M										
20D/30D		DC-30W	D										
81/82		DC-30W	All Except F/M										

Spools

B-SOLENOID

A-SOLENOID

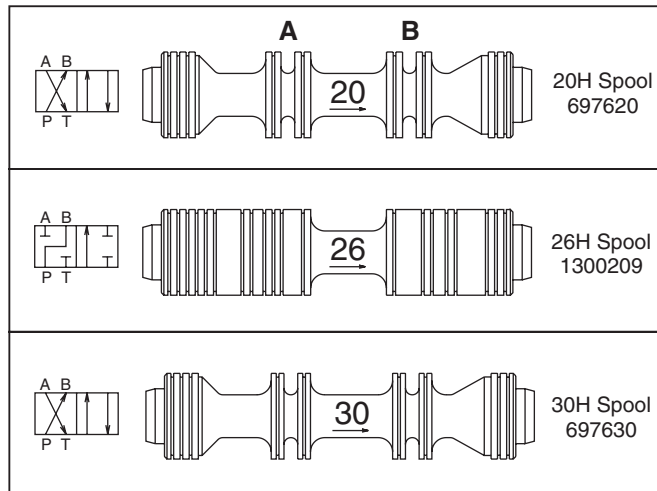

Variation 56 – Single Solenoid Plug-in Models with Lights and 3-Pin Manaplug (Mini)

Valve	Spool	Nameplate Marking	Wiring Diagram	Sol. Code	Item	Part Number	Qty	Description
D1VW	All Spools Except 008 and 009			A L L	1	1302151	1	Manaplug, 3-Pin
					2	1800707	1	Warning Label
					4	1800610-4	1	Conduit Box Cover
					5	1800611	1	Nameplate
D1VW	Spools 008 and 009 Only			A L L V O L T A G E S				
D1VW	All Spools Except 008 and 009							
D1VW	Spools 008 and 009 Only							

● Wiring diagrams show the backside of plug.

Variation 1C – Single Solenoid Plug-in Models with Lights and 5-Pin Manaplug (Mini)

Valve	Spool	Nameplate Marking	Wiring Diagram	Sol. Code	Item	Part Number	Qty	Description
D1VW	All Spools Except 008 and 009			A L L	1	1302154	1	Manaplug, 5-Pin
					2	697629	1	Warning Label
					4	1800610-4	1	Conduit Box Cover
					5	1800611	1	Nameplate
D1VHW	Spools 008 and 009 Only			A L L V O L T A G E S				
D1VHW	All Spools Except 008 and 009							
D1VW	Spools 008 and 009 Only							

● Wiring diagrams show the backside of plug.

Plug-in Conduit Variation

Valve	Spool	Nameplate Marking	Wiring Diagram	Sol. Code	Item
D1VW	All Spools Except 008 and 009			A L L	1
D1VW	Spools 008 and 009 Only				2
D1VW	All Spools Except 008 and 009			A L L V O L T A G E S	4
D1VW	Spools 008 and 009 Only				5

☉ Wiring diagrams show the backside of plug.

Note: H, K and M styles shown

Wiring Instructions

(Dashed lines indicate wiring thru terminal strip – no assembly required here)

1. Install manaplug (Item 1) over solenoid "A" on double solenoid models (opposite solenoid on single solenoid models).
2. Slip ground screw (1301070) through ring terminal on green ground wire (from manaplug) and secure to valve body.
3. Insert manapug wires into terminal strip (Item 3) in box as shown in wiring diagram. Ensure all wire strands are contained by the connector and tighten clamping screws to 0.5 Nm (5 in. lbs.).
4. Install cover on the conduit box.
5. Place warning label (Item 2) on conduit box side, as shown.

Solenoid Ratings

Insulation System	Class H
Allowable Deviation from rated voltage	-15% to +10% for DC and AC rectified coils -5% to +5% for AC Coils
Armature	Wet pin type
CSA File Number	LR60407
Environmental Capability	DC Solenoids meet NEMA 4 and IP67 when properly wired and installed. Contact HVD for AC coil applications.

Explosion Proof Solenoid Ratings*

UL & CSA (EU)	Class I, Div 1 & 2, Groups C & D Class II, Div 1 & 2, Groups E, F & G As defined by the NEC
MSHA (EO)	Complies with 30CFR, Part 18
ATEX (ED)	Complies with ATEX requirements for: Exd, Group IIB; EN50014: 1999+ Amds. 1 & 2, EN50018: 2000

* Allowable Voltage Deviation ±10%.

Note that Explosion Proof AC coils are single frequency only.

Code		Voltage	In Rush Amps Amperage	In Rush Amps D1VW VA	Holding Amps D1VW @ 3MM	Watts D1VW	Resistance D1VW
Voltage Code	Power Code						
D	L	120 VDC	N/A	N/A	0.09 Amps	10 W	1584.00 ohms
			N/A	N/A	0.26 Amps	30 W	528.00 ohms
G		198 VDC	N/A	N/A	0.15 Amps	30 W	1306.80 ohms
J	L	24 VDC	N/A	N/A	0.44 Amps	10 W	51.89 ohms
			N/A	N/A	1.32 Amps	30 W	17.27 ohms
K	L	12 VDC	N/A	N/A	0.88 Amps	10 W	12.97 ohms
			N/A	N/A	2.64 Amps	30 W	4.32 ohms
L	L	6 VDC	N/A	N/A	1.67 Amps	10 W	3.59 ohms
			N/A	N/A	5.00 Amps	30 W	1.20 ohms
Q	F	100 VAC / 60 Hz	1.70 Amps	170 VA	0.56 Amps	24 W	26.0 ohms
QD	F	100 VAC / 60 Hz	1.35 Amps	135 VA	0.41 Amps	18 W	31.2 ohms
QD	F	100 VAC / 50 Hz	1.50 Amps	150 VA	0.57 Amps	24 W	31.2 ohms
R	F	24/60 VAC, Low Watt	6.67 Amps	160 VA	2.20 Amps	23 W	1.52 ohms
T	F	240/60 VAC, Low Watt	0.70 Amps	168 VA	0.22 Amps	21 W	145.00 ohms
T	F	220/50 VAC, Low Watt	0.75 Amps	165 VA	0.26 Amps	23 W	145.00 ohms
U		98 VDC	N/A	N/A	0.10 Amps	30 W	960.00 ohms
Y	F	120/60 VAC, Low Watt	1.40 Amps	168 VA	0.42 Amps	21 W	36.50 ohms
Y	F	110/50 VAC, Low Watt	1.50 Amps	165 VA	0.50 Amps	23 W	36.50 ohms
Z	L	250 VDC	N/A	N/A	0.04 Amps	10 W	6875.00 ohms
			N/A	N/A	0.13 Amps	30 W	1889.64 ohms
Explosion Proof Solenoids							
R		24/60 VAC	7.63 Amps	183 VA	2.85 Amps	27 W	1.99 ohms
T		240/60 VAC	0.76 Amps	183 VA	0.29 Amps	27 W	1.34 ohms
N		220/50 VAC	0.77 Amps	169 VA	0.31 Amps	27 W	1.38 ohms
Y		120/60 VAC	1.60 Amps	192 VA	0.58 Amps	27 W	33.50 ohms
P		110/50 VAC	1.47 Amps	162 VA	0.57 Amps	27 W	34.70 ohms
Q		100/60 VAC	1.90 Amps	192 VA	0.70 Amps	27 W	38.60 ohms
K		12 VDC	N/A	N/A	2.75 Amps	33 W	4.36 ohms
J		24 VDC	N/A	N/A	1.38 Amps	33 W	17.33 ohms
D		120 VDC	N/A	N/A	0.28 Amps	33 W	420.92 ohms
Z		250 VDC	N/A	N/A	0.13 Amps	33 W	1952.66 ohms

Warning

Before any circuit connection is broken, be sure to turn off all power and relieve system pressure. Lower all vertical loads and cylinders, lock any load which could produce pressure and discharge any accumulators. Plug and cap all lines and openings to prevent contamination from entering the system.

Cleaning and Inspection

1. Proper cleaning is a critical part of preventive maintenance in the use of directional control valves. All parts should be cleaned with a solvent that is compatible with the system fluid. Compressed air may also work well when cleaning orifices and passage ways, but proper filtration must be employed to remove water and contamination.

NOTE: Always make sure all parts have been cleaned before reassembling.

2. Inspection

- a. Inspect all passage ways for obstructions.
- b. Inspect all washers, push pins, plungers and pole faces for signs of wear and/or mushrooming. Inspect all springs for signs of distortion. Replace parts as necessary.
- c. Look for nicks and burrs on the spool and bore lands. Nicks in these areas indicate likely contamination of the system fluid.

3. If there are no signs of nicks or burrs on the spool and bore, check the spool clearance as follows:

- a. Lubricate the spool and bore with clean system fluid.
- b. Insert the spool back into the body and slowly move the spool back and forth. The spool should move freely. If there is any sticking between the spool and the bore, remove the spool and repeat 2b.
- c. The spool clearance can also be checked by placing the valve body on end and inserting the spool. Gravity will pull the spool to the other end if there is no sticking.
- d. After several attempts have been made without resolution, replace the valve.

Troubleshooting

Problem: Valve spool fails to move

	Cause	Recommendation
Mechanical	Recommended flow exceeded	Check maximum flow rate for appropriate spool by spool function.
	Recommended pressure exceeded	Check maximum pressure rating for valve.
	Improper installation connections	Check installation drawings.
	Contamination in system	Disassemble, inspect, clean and flush.
	Improper assembly	Check proper assembly. Refer to drawing for appropriate model.
	Valve has silted	Disassemble and clean valve.
Electrical	Power off	Turn power on.
	Improper voltage	Check voltage requirements for valve model.
	Faulty connection	Check connections.
	Faulty coil	Check coil resistance.

Problem: Valve produces undesirable response

	Cause	Recommendation
Mechanical	Recommended flow exceeded	Check maximum flow rate for appropriate spool by spool function.
	Recommended pressure exceeded	Check maximum pressure rating for valve.
	Improper installation connections	Check installation drawings.
	Contamination in system	Disassemble, inspect, clean and flush.
	Improper assembly	Check proper assembly. Refer to drawing for appropriate model.
	Improper fluid	Check fluid recommendations.
	Recommended temperature exceeded (indicated by fluid discoloration or spool tarnishing)	Check maximum temperature recommendations.
	Incorrect orifice size (soft shift only)	Check orifice size for desired response time.
Electrical	Improper voltage	Check voltage requirements for valve model.
	Faulty connection	Check connections.
	Faulty coil	Check coil resistance.



Parker Hannifin Corporation
Hydraulic Valve Division
520 Ternes Avenue
Elyria, Ohio, 44035 USA
Tel: (440) 366-5200
Fax: (440) 366-5253
www.parker.com/hydraulicvalve

Bulletin HY14-2536-M6/US,
600, 4/07, PHD